

# Building *with* steel

## Part 1: Why choose steel?

*In the first of a three part series, we discuss why steel can be a good choice for your build.*



Owner builders may be driven by many different things, but all have one thing in common – the time and motivation to select construction materials on the basis of their contribution to the finished project. This is particularly in evidence when it comes to the structure of the building, an area most homebuyers leave entirely to the builder. It's your money though, and what it gets spent on can have cost and benefit consequences throughout the life of the home.

When it comes to framed construction – the most common choice for Australian homes – the contribution of the frame to the durability and longevity of the home is immense. The frame bears or transfers almost all loads to which the home is subjected, and also supports all cladding and lining materials and most fixtures. Failure of the frame to fulfil these functions in any part of the home can have serious consequences. Steel framing means a long life, trouble free frame that will not warp, burn or rot.

The frame of the home should always be made from durable materials that will resist all forms of environmental attack. Any part of the structure made from anything else should be easy to inspect in order to assess and rectify any deterioration. The manner in which most homes are designed and constructed makes this inspection difficult and costly for many parts of the frame, including wall frames, intermediate floor framing and lined rafters in sloping ceiling structures.

The frame's contribution to the serviceability of the building is also significant. It provides the strength, stiffness and geometric stability of the building. Its ability to stay straight and square indefinitely, through

varying seasons with temperature and humidity changes, is vital to just about everything which is attached to it – the exterior skin (brick or other cladding), roof tiles or sheeting, window units, door frames, plasterboard wall linings and so on. Superficial and so-called 'nuisance' defects, like sticking doors and windows, brickwork and cornice cracks, nail popping in wall linings and sagging roof lines, can often be traced to instability in the frame and contribute to the overall cost of ownership.

### Advantages for homebuilding

When strength, durability and quality are the important selection factors, steel framing is the natural choice for brick-veneer and direct-clad home construction. Steel framing offers outstanding homebuilding advantages:

**Durability:** You need never be concerned that the structural frame you can't see is deteriorating due to environmental or biological attack by termites, borers or fungi.

**Stability:** Steel frames will not absorb moisture or dry out. Steel has outstanding dimensional stability to keep your home in shape indefinitely.

**Structural efficiency:** Engineered steel frames are extremely strong yet are light in weight.

**Design flexibility:** Create optimum architectural forms to suit your living needs and building conditions, including long clear spans for open plan living and even curved trusses.

**Wide availability:** The design you want can be built virtually anywhere in Australia.

**Fire resistance:** Does not burn nor contribute fuel to the spread of a fire.

**Low maintenance:** Low cost and effort to keep its design qualities intact.

**Trade familiarity:** Steel frames are easy to construct and finish, and you'll always have access to the skills to modify or extend your home.

**Environmentally friendly:** Steel is 100% recyclable, easily accommodates energy efficient design concepts, enables minimal site disturbance and produces little site waste.

*Ed's note: Building Code of Australia 2008 Volume 2 Part 3.1.3 Termite Risk Management states that no termite barrier is required if a building has all of its primary building elements (designed specifically to take part of the building load) constructed of one, or a combination of, the following materials: steel, concrete, masonry, fibre-reinforced cement, naturally termite resistant timber, or preservative treated timber.*

### Advantages for owner builders

Whether you plan to do much of the work yourself or simply supervise your trade contractors, steel house framing is especially attractive to the owner builder. Nearly all frame suppliers produce installation manuals or sets of instructions, and some basic instructional videos. As steel framing is an engineered product, it is important to adhere strictly to the supplier's instructions on the number and positioning of fasteners, brackets, bracing etc. The owner builder will particularly benefit from the following steel framing advantages:

Steel framing is **light but strong**. There is less mass of material to be handled on site at frame stage, so it is safe and easy to handle and quick to erect.

Steel framing fabricators supply **prefabricated** frame sections in easily transportable and manageable panels and trusses.

Frame erection is **simple**. All components are identified to ensure the correct erection sequence.

**Connections** are quick and easy using screws, bolts and rivets applied with tools from any hardware store.

Verifiable **quality**. Steel is a consistent, engineered product free of natural imperfections.

Steel framing is **versatile and adaptable**. Depending on the home's architectural design, you can choose steel framing for part of it and combine it with other structural materials. At every stage and for every detail, it's your choice.

## Limitations

Steel is an extremely durable long life material. Nevertheless, there are certain environments and situations where it may be unwise to use standard steel framing products without expert advice. Fortunately these are very few, and will affect only a small number of intending homebuilders.

Generally speaking, where steel is unsuitable you will also find some limitations on the use of other homebuilding materials including aluminium, tiles and bricks. The main environments where precautions are advisable are marine and heavy industrial areas.

For marine environments, the Building Code of Australia Volume Two (Housing Provisions) specifies that metallic coated steel comprising 275 grams of zinc per square metre (Z275) or 150 grams of aluminium/zinc per square metre (AZ150) may be used for steel framing that is fully enclosed within the building envelope, beyond 300 metres from breaking surf conditions. Where the framing is outside the building envelope, such as sub-floor or exposed verandah framing, the same metallic coated steel may be used: beyond 1km from calm salt water, such as a lake or estuary; or beyond 10km from a coastal area with breaking surf.

Breaking surf normally occurs in areas exposed to the open sea, with regular breaking of waves about four days per week. It doesn't include choppy, white-capped water.

If you are proposing to build closer to an adverse environment than these distances, painting systems are available to increase the corrosion resistance of steel.

## Living with steel

Apart from the frame, there is a wide variety of factory pre-painted architectural steel products available when you reach the finishing stages of your project. These products inherently have a very long low-maintenance life, which is particularly helpful on the higher parts of your home where maintenance access is difficult or hazardous.

Much of the environmental impact of buildings is determined at the design stage, through materials decisions, inbuilt efficiencies and performance criteria incorporated into the design. It is therefore important that environmental impacts be considered early in the design process, where the greatest potential is available for influencing outcomes.

Virtually all steel products used in residential construction are highly recyclable, contributing to steel's reputation as the most recycled metal on the planet. Steel generates a very low mass and volume of construction waste, and the small amount finding its way to landfill is basically inert and non-polluting.

*Ed's note: Framing steel is fully recyclable and contains approximately 20% recycled materials. Methodologies and opinions vary on the assessment of the embodied energy of construction materials. The embodied energy due to the manufacturing process is still considered by some to be higher for steel than for timber framing. The longevity of steel framing along with the advantage of not having to use preservative-treated timber are two of many factors to be considered in the overall equation of lifecycle energy consumption.*

## Tools required

Steel framing requires a surprisingly small number of tools – many of which you may already own – for successful owner builder construction. You won't need anything that can't be bought at a good hardware store or that requires special training to use safely. Most tools and techniques are the same as for timber framing or masonry construction: string lines, T-square, levels, drills, hammers, screws, nails etc.

It's always advisable to invest in good quality tools, or to hire specific items for particular jobs. This will be discussed in more detail in part 2, but the following

basic items will stand you in good stead throughout your project:

- A good quality battery screwdriver – 14.4 or 18 volt – with at least one spare battery
- An angle grinder of comfortable size and weight, typically 100mm disc diameter
- A pair of articulated snips
- Several toggle clamps

## Getting started

To start the process, all that is necessary is for you to have a designer/architect prepare drawings of your house or extension, showing details such as floor layout, elevations and room dimensions. The frame supplier will be able to quote you a price for the structural frame, including floor, wall and roof framing, and this will usually include any required beams or columns. The scope of supply and the range of included materials will vary slightly from place to place, so be sure that you and your designer are quite specific as to what you require and verify what is included. The frame supplier will also be able to supply all the necessary components such as brackets, fasteners, and grommets from the same basic design information. ■

**Part 2** of the series will cover the basic techniques for setting out and constructing a steel frame. **Part 3** will then concentrate on finishing: how to fit windows, doors, roofing and cladding materials.

Thanks to National Association of Steel-Framed Housing Inc (NASH) and Technosteel Australia for the information provided for this article.



### • NASH

A good source of information on suppliers and technical information. Visit their website for up to date information on residential and low-rise steel framed construction.

Training is offered at some TAFEs for trades people wishing to gain expertise with steel framing. These courses may be suitable for owner builders with some experience in building.

1800 656 986, [www.nash.asn.au](http://www.nash.asn.au)

### • Technosteel Australia

Manufacturer of steel house frames, roof trusses and floor systems, mainly for the owner builder.

1300 553 457,

[www.technosteelaustralia.com](http://www.technosteelaustralia.com)



PHOTO: COURTESY NASH



PHOTOS THIS PAGE: COURTESY TECHNOSTEEL, EXCEPT AS INDICATED



# Building *with* steel

## Part 2: Now you're underway

*In the second of our three part series, we discuss the practical construction aspects of building a steel framed home. This is meant as a general guide only - you should always follow your designer's specifications and frame supplier's instructions and seek expert advice and help along the way.*

Humans used to live in caves and similar geological formations. Caves are natural structures and may be over- or under-designed, with whatever features nature has provided. Houses, on the other hand, are engineered structures. Everything in them is there for a purpose, whether it be structural, functional or aesthetic. The frame supplier normally takes responsibility for the structural engineering of the frame.

When it comes to the structure, nothing should be left to chance; it should be properly designed, installed, finished, protected and maintained. Everything depends on the structure - the security, comfort and amenity of its occupants as well as its investment value. Building the structure correctly is never an extravagance, and cutting corners is always a mistake.

### Footings

Accuracy is always beneficial in construction - remember that your ability to compensate for previous inaccuracies is not guaranteed

throughout the project, so getting it right at every step will save you a lot of time and angst later on!

The most common footing types supporting steel framed construction are concrete slab-on-ground, and steel or concrete stumps or brick piers on concrete pad footings.

Concrete slabs are designed to support building weight (dead load), provide hold down and resistance to overturning, resist termite entry and provide a trafficable floor for occupancy. We won't cover concrete slabs here, except to say that slab design and construction is basically identical for all types of construction.

Concrete strip and pad footings with piers or stumps (posts) must perform the same support, hold down and overturning resistance as a concrete slab. They are used with suspended floor construction, i.e. where there is a subfloor space. Footings of this type are normally set out to a grid with a regular spacing, based on the spanning capacity of the floor bearers used in the design. The steel stump supplier will provide recommended installation details for

stumps, including the required accuracy of set out where stumps are not adjustable in height.

### Floor framing

With the footings in place, the next step is to install the floor framing. The most common steel floor framing system consists of C-section bearers spanning between posts with C- or top-hat section joists laid over the bearers. Floor system manufacturers will provide all required installation instructions.

To save time and effort later, it is a good idea to mark out the positions of the floor joist on the bearers before lifting into place, particularly if the top of the bearers will be above eye line after they are fixed to the supports. Sort the bearers for size, length and location. Lay them beside each other, keeping the ends flush, and mark out the positions of the floor joist on the first bearer. Transfer these positions to the other bearers using a square. The bearers can now be laid out beside the posts in accordance with the manufacturers or fabricators drawings.

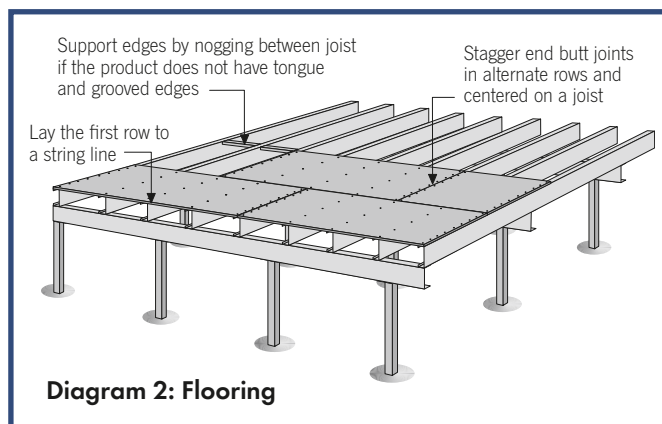
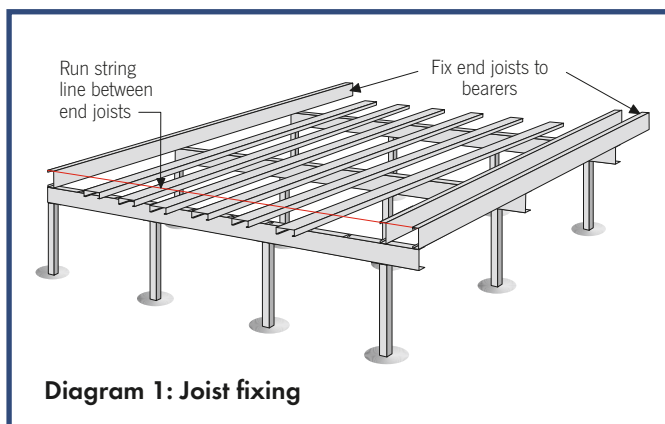

Depending on the particular system, the bearers may be bolted or screwed to the posts. The bearers are placed onto the support posts one at a time, checking that they are correctly positioned as shown on the structural plans. For bolted systems, mark the positions of the bolt holes in the posts onto the bearers, and drill the appropriate size holes in the bearers. Place back on to supports, insert the bolts (including any required washers) and tighten. For screw fixed systems, check the positioning as described above and fix with the specified screws. Repeat these procedures until all bearers are fixed in place.

Joist fixing is generally quite straightforward. Sort the joists for size, length and location and place them, on their flat, into their approximate positions. Joist spacing is determined by the spanning capacity of the joists and of the strip or sheet flooring that will be fixed to them. Starting with the end joists, check that both ends of the joist are flush with the bearers or have the required cantilever. Using the specified connections fix both end joists to the bearers, and run a string line between these joists. Continue fixing the other joists using the string line to keep the ends in line. See **diagram 1**.

## Flooring

Steel floor framing is an ideal substrate for all kinds of flooring material such as strip timber, structural particleboard, fibre cement and plywood. See **diagram 2**. These materials come in different thicknesses to suit different joist spacings. Most fixing is done with a combination of adhesive and screws or nails. For specific information on



fixing a particular flooring product, always follow the flooring product manufacturer's recommendations.

## Wall framing

Wall locations are set out on the slab or platform using a chalk line, starting with the external walls. To compensate for possible differences in slab dimensions, it's best to mark the inside of the external wall frame positions. Continue on to the internal walls, checking constantly for squareness.

Where perimeter wall frames are placed on a concrete slab-on-ground, a durable impermeable membrane should be placed between the bottom plate of perimeter wall frames and the slab and extend up the weather side flange of the bottom plate. The membrane is not required beneath internal wall frames. The membrane may be the same as that used for damp-proof courses, a paintable bitumen product or a self-adhesive polyethylene.

To save time and effort later, it is a good idea to mark out the positions of the roof trusses on the top plates before

standing the frames. Any holes in the bottom plate that may be required for fixing to the slab/floor frame can also be made. To make the removal of the bottom plates in doorways easier after the frames are erected, cut the web of the bottom plate either side of the doorways using an angle grinder with a metal cutting disc or preferably with a power saw with a cold-cutting metal blade. See **diagram 3**.

When all wall locations are marked out and the frames prepared, place the frames near their required location as shown on the layout plan. Stand the frames commencing with an external corner, fixing them together as recommended by the frame supplier. This is typically done with self-drilling screws. Continue to work around the building adding one frame at a time, checking that each frame is aligned with the set out marks and plumb before proceeding to the next. On longer walls, temporary bracing is essential to stabilise the frames until the wall and roof framing is complete and fully braced.

The frames are then fixed down to the slab or floor using methods and spacings specified by the frame supplier.

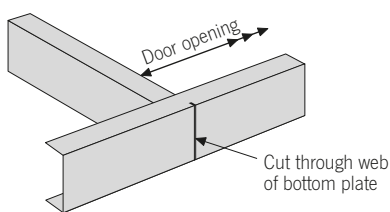

**Diagram 3: Preparation of bottom plates for openings**



## Temporary bracing

Wall panels, roof panels and trusses help to stabilise each other in the finished frame structure. During construction, they may need temporary propping to prevent collapse and to ensure secure footing for installation workers. You should ensure that there is always sufficient support for the freestanding structure – wall panels and roof trusses – by adding temporary props or bracing as required. If in doubt, add more! Typically every wall panel or truss should be individually propped until it is secured to the permanent, fully braced structure. This is particularly important for long runs of walls, gable end walls or large truss spans.

## Housekeeping

On completion of each stage of construction, the area should be cleared and waste material disposed of safely and responsibly. Any excess materials should be stacked and stored to allow for use at a later date.

Self-drilling screws create steel 'swarf' as they drill. Whilst not hazardous in small quantities, when swarf gets into the wrong places it can mar the appearance of coated steel surfaces. It's a good idea to sweep away swarf progressively as you work, along with any discarded screws and small off-cuts, to minimise any adverse effects.

The channel shaped bottom plate of steel wall framing panels will tend to accumulate construction debris and should be kept clean during the works.

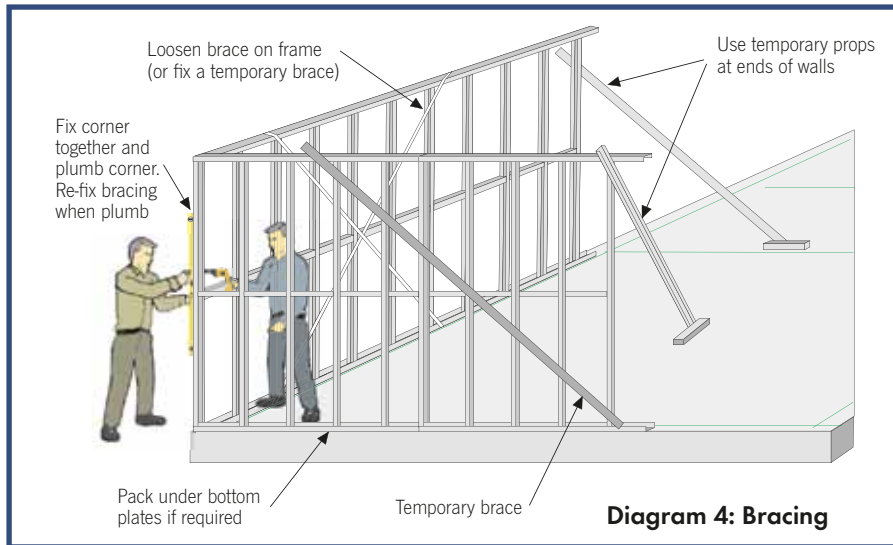

The specifications will vary depending on the type of floor, type of roof and wind region. Particularly important are the fixings beside openings, at wall ends and corners, and where bracing straps or sections meet the bottom wall plates. Screw bolts are a common fixing method to concrete slabs as they are fast and reliable. Where a steel floor frame is used, self-drilling screws of the correct size and length are commonly used.

In cyclonic areas where hold down requirements can be very large, your frame supplier will pay particular attention to the continuity of the load path from roof structure to foundations. This may involve specialised fastening arrangements for the wall frames.

## Bracing

Bracing strength is critical to the structure both during and after construction. Bracing usually consists of a combination of methods such as metal strapping, sheet materials such as steel, fibre cement or plywood, and plasterboard lining. You will need to provide and fix all bracing as specified by the frame supplier. See **diagram 4**.

The final step in wall framing is to remove the bottom plates in doorways, a job made much easier if the plate webs have been pre-cut as described earlier.

## Roof framing

There are two types of steel roof framing system in common use in Australia: panel systems and truss systems. Panel systems consist of ceiling panels and roof panels, and can be likened to 'inclined walls' in which the studs act as

ceiling joists or roof rafters. Truss systems are more familiar, with geometry generally similar to their timber counterparts.

Truss systems are installed by placing each truss at its 'station' on the wall plates, working to the roof layout plan provided by the fabricator. The first truss is temporarily propped and stabilised, and each subsequent truss is stabilised back to the previous one. See **diagram 5**. A temporary bottom chord brace is installed to ensure the trusses remain in place during construction.

## Roof battens

For safety and to save time and effort later, where a sheet roof is to be fitted it is a good idea to mark out the positions of the roof battens on the top chords of the trusses before lifting the trusses into place. With the roof structure in place, the battens can be set out to suit the roof cladding.

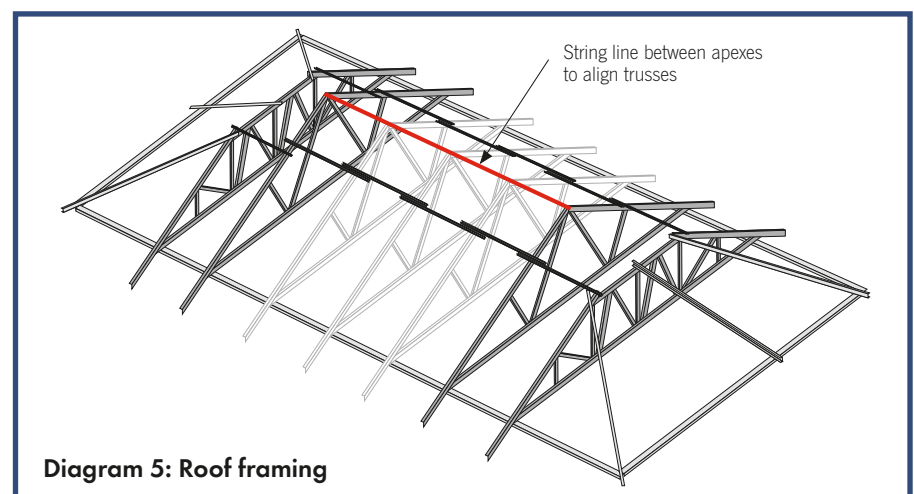

## Safety

All electrically conductive sections of steel structural frames should be earthed in accordance with the requirements of the local electricity authority. As soon as practical in the frame erection process, a temporary earth should be established until the permanent earth is installed.

There are good battery powered screw guns and other tools that largely remove the need for using power leads. On all construction sites and with all forms of construction, electrical power leads should be kept in good condition and regularly checked. Wherever possible, leads should run overhead and not along the ground.

Guidance on safe methods of construction is available from your local workplace safety authority.

## Required tools

As mentioned in the first article, the tools required for steel frame construction are familiar and readily available. This is what you're likely to need:

- A good quality battery screwdriver
- A small angle grinder
- A pair of articulated snips
- Several toggle clamps
- String lines and chalk lines
- A masonry drill (if building on a concrete slab)
- A good quality level at least one metre long
- General hand tools. ■

Part 3 of this series will cover finishing: fitting windows, doors, roofing, cladding and linings. Thanks to National Association of Steel Framed Housing Inc (NASH) for the editorial and diagrams, and to Technosteel Australia for the photographs.



### • NASH

A good source of information on suppliers and technical information. Visit their website for up to date information on residential and low-rise steel framed construction. Training is offered at some TAFEs for tradespeople wishing to gain expertise with steel framing. These courses may be suitable for owner builders with some experience in building. 1800 656 986, [www.nash.asn.au](http://www.nash.asn.au)

### • Technosteel Australia

Manufacturer of steel house frames, roof trusses and floor systems, mainly for the owner builder. 1300 553 457, [www.technosteelaustralia.com](http://www.technosteelaustralia.com)



## Subscriptions to *The Owner Builder* are now also available as an electronic PDF file

A great new way to read your favourite magazine – as a fully searchable and printable PDF file sent direct to your email address!

To subscribe, see order form on p.48

THE FOLLOWING OPTIONS ARE AVAILABLE:

**A. PDF file only** – \$33.00 for a year's subscription (6 issues). Receive your magazine as an electronic PDF file, via email. See note below.

**B. Printed magazine plus PDF file** – \$55.00. Reap the benefits of full PDF searchability, while retaining the unique look and feel of the hard copy magazine.

*NOTE: The PDF file is generally around 8-9MB in size. You will need a broadband connection, and an email system that allows you to receive attached files up to 10MB in size.*

**Hard copy only** – \$38.50. Of course, we will continue to offer the option of just a physical hard copy of the magazine every two months, as usual. Save 7.5% on the recommended retail price by subscribing.

If you would like to upgrade an existing subscription to a PDF option, please contact us by phone on 02 4995 8821 or email: [info@theownerbuilder.com.au](mailto:info@theownerbuilder.com.au)

## Win a solar system valued at up to \$14,000

### ReNew

- renewable energy
- sustainable building
- water conservation
- DIY projects



### Join ATA and receive:

- free subscription to **ReNew**
- free advice service
- discounts from over 50 suppliers of sustainable products and services

For only \$65 or \$40 (conc.)

[www.ata.org.au](http://www.ata.org.au) or call (03) 9639 1500

## PERMACULTURE DESIGN COURSES



Southern Cross Permaculture Institute  
With RICK & NAOMI COLEMAN Dip Pc

- Residential 13 day course on established site with internationally recognised teachers
- 7710 Bass Hwy Leongatha, Victoria
- Next PDC: SCPI 6–21 March 2009

[www.southerncrosspermaculture.com.au](http://www.southerncrosspermaculture.com.au)

### Tas – January

Huonville. Contact Celia: [celialev@iinet.net.au](mailto:celialev@iinet.net.au)

### Tas – April

Flinders Island. Contact Scott: [scott@greengoddess.net.au](mailto:scott@greengoddess.net.au)

Call for a brochure on 03 5664 3301 or email [scpi@activ8.net.au](mailto:scpi@activ8.net.au)

Cost: \$1050. Includes morning teas and lunches • Free camping • Work exchange available.

First 10 people get free Mollison book.

10% discount for couples • Half price offer if you've done a PDC before.



# Building *with* steel

## Part 3: The final straight

*In the third and final part of our series, we discuss the finishing operations on your steel framed home. As with earlier articles, this is meant as a general guide only, and some practices may vary from place to place. You should always comply with local regulations (especially for services), follow your designer's specifications and frame supplier's instructions and seek expert advice when you need it.*



Your steel frame is now structurally complete and ready to support the roofing, cladding, lining, fit out components and services that will turn it into a dwelling. All of these items have particular fixing requirements to ensure a sound, serviceable and aesthetically pleasing finish. If you have built the structure carefully and accurately, you can expect few problems in the finishing stages.

The exact sequence of finishing operations may vary from house to house. The sequence described here is the one most commonly used. We've also added some of the general principles of thermal efficiency and condensation; although these are not specific to steel framed construction, they are things you need to consider before or during the finishing stages.

### **Fascia and guttering**

Modern pre-painted steel fascia and gutter systems are quite straightforward to install and come with many accessories to make the job easy, whether you decide to do it yourself or have them installed by an expert. You can also use timber fascia if you are confident it will have sufficient stability and durability for your project. Fascia brackets are screwed to each truss or rafter and the fascia clipped to the brackets. The exact design and accessories vary with the fascia system, and the manufacturer's instructions should be followed. Gutters are usually clipped to the fascia with a combination of clips and overstraps. Note that in

---

*Frame prior to final fit out.*

some states only licensed plumbers can install rainwater drainage systems, so always check the local situation before deciding what to do yourself.

## Roof tiling

The basic processes of sarking, battening and tiling a steel roof structure are basically the same as for timber framing, but there are differences between systems such as the spacing of trusses and the size and shape of the battens. Working at heights is not for everyone, and should be left to the experts in most cases.

Tile clips are used to secure roof tiles to steel or timber battens, at a frequency specified in the Building Code of Australia (BCA). Clips are usually supplied by tile manufacturers to suit specific tile and batten combinations. L-shaped clips are most commonly used to secure the side-lap of the tile where the lower or 'nose' end sits on the top or 'back' end of the lower tile. U-shaped clips are sometimes used at the back end of the tile, performing a similar function to nails used with timber battens, but are less effective as they do not stop the nose of the tile lifting in wind gusts. Tile clips are typically made from galvanized wire. Tiles may also be screwed to steel battens.

## Roof sheeting

There are no unusual requirements for installing steel roof systems to steel framing. A typical installation is comprised of steel 'top hat' battens, insulation foil/blanket and steel roof sheeting. With sheet roofing the insulation material always goes between the sheeting and battens, which differs from tiled roofing where it is placed below the battens.

The type and frequency of screw fastening varies depending on the sheet profile and the wind region of the site. Always follow the manufacturer's recommendations. Note that in some states only licensed plumbers can install steel roofing.

## Windows and doors

Windows, doors and their associated accessories and trims are exactly the same for steel and timber framing of the same wall frame depth. As these depths vary regionally for both timber and steel, make sure you specify the correct jamb, frame or reveal width when ordering windows.

The window and door openings in framed construction are designed on the assumption that the wind forces on the window or door are transferred to the jambs and sill and not to the head (top) frame member. Similarly, window and door units are not intended to bear loads anywhere on their top frame member. Therefore it is important when installing all window and door units to leave a clear gap of typically 20mm between the structural frame and the top frame of the door or window unit. This gap will be covered by the architrave internally, and by a storm mould or trim externally. Compressible thermal insulation may be placed in the gap if required.

## Brickwork

Masonry veneer with steel or timber framing is the most common form of residential construction in Australia. The masonry skin is stabilised by the frame, to which it is connected by steel or nylon ties embedded in the mortar joints. The ties may be fastened to the sides or face of the steel studs, with face fixing being more common when bracing sheets or insulation boards are installed.

The strength, durability and fixing frequency of brick ties for various building conditions are specified in the BCA.

## Exterior cladding

Various types of lightweight cladding, such as fibre cement sheet, hardboard and steel, are commonly used on walls, gables and feature panels, especially in upper floor construction where low mass has a structural advantage. Typically these materials are fixed with screws or clips recommended by the manufacturer. Steel framing provides a stable, durable substrate for these materials.

## Plumbing services

The BCA does not regulate electrical wiring or plumbing in housing, except to ensure that the installation of these services does not cause damage to the structure. The BCA requirements in this regard are that:

- Services must pass through pre-punched service holes or through extra holes located near the centreline of studs – the structurally safest place.



Air-Cell Permishield used as building wrap.

- Copper and brass pipes and fittings must be isolated from steel framing to prevent corrosion.
- Plastic grommets must be used where copper and brass pipes pass through service holes in steel framing.

Where plastic plumbing pipes and fittings are used, there is no requirement for isolation from the steel frame, but pipes should always be protected from damage due to sharp corners or edges. This applies equally to timber and masonry construction, where services pass near or through bracing straps, brackets, ties and other metal components. Flared or grommets holes are designed to protect plastic pipes from damage where they pass through steel framing members.

All plumbing pipes and fittings should be securely fastened to prevent water hammer. Services are sometimes placed in the cavities of brick veneer walls, but some local authorities may not allow this due to the risk of the cavity being breached by mortar and other debris. Plumbing services should be carried out by licensed contractors who will be familiar with the requirements of their trade.

## Electrical services

In all buildings including houses, electrical services should be installed in accordance with the relevant Australian Standards by an appropriately licensed contractor. Where cables need to pass through plain holes in steel framing members, plastic grommets are used to protect the cables. Flared holes placed by some manufacturers are designed to



provide protection without the need for grommets. Manufacturers usually provide multiple holes in studs and plates to make wiring and plumbing easier for contractors.

### **Interior lining**

Plasterboard linings in a steel framed building are fixed with a combination of adhesive and bugle head screws – the same adhesive is used for both timber and steel construction. Fibre cement interior lining is fixed with adhesive and self-embedding head screws. In areas that will be ceramic or porcelain tiled, lining manufacturers usually recommend using screws only.

### **Skirtings and architraves**

Installation of skirtings, architraves and trim is normally done with specific screws for each job, such as countersunk head extended drill point screws. These should be readily available from normal hardware stores or fastener distributors.

If you are confident with power nailing tools, hardened pneumatic driven nails specially developed for steel framing are available for use in air powered nailing guns. These nails can be used to fix timber window and door jambs, architraves and skirting to the steel frame.

*Above L-R: Wall cladding being fixed to steel frame; attaching fascia and gutter to steel frame.*

---

### **Thermal insulation**

The BCA sets performance levels for the thermal performance of buildings. These requirements may be met by either using deemed-to-satisfy thermal ratings in the walls, roofs and floors or using an approved computer software program to demonstrate compliance. In either case, the thermal performance of the building envelope will need to be considered and in most cases, some form of insulation will be required.

In the walls, board systems can be fixed to the external face of the stud or bulk insulation e.g. glass fibre, wool, cellulose fibre or polyester can be placed between the studs to achieve the required rating. In both cases reflective foil can be used to assist with the performance of the wall. It is highly desirable that the building wrap be vapour permeable so that any vapour in the cavity can escape. Similar insulation systems are available for roofs, and building wrap placed below external roofing should always be vapour impermeable.

The insulation requirements are independent of the type of structural frame. With lightweight claddings such as fibre cement, hardboards and steel, it is required that a thermal break be

provided to the wall stud. An acceptable solution is the attachment of a 12mm expanded polystyrene (EPS) strip to the external face of the stud. Other proprietary systems can also give the required performance (R=0.5). Thermal breaks may also be required where the roof cladding and lining are both fixed to a common batten. The thermal break is not required with brick veneer and other similar forms of construction.

In all climates, the area and orientation of glazing and extent of shading is one of the biggest influences on the thermal performance of the building. An external wall with a total R-value of 2 will insulate 12 times better than basic clear single glazing. Well designed glazing provides the opportunity to achieve greater energy efficiencies through reducing the need for heating in cooler climates, minimizing heat gains in hotter weather, allowing air movements for cooling in hotter weather and providing natural light.

### **Condensation**

When moist air comes in contact with cold surfaces such as windows and walls, condensation can form. This can lead to problems of mould growth and in extreme cases affect the durability of susceptible materials. As modern buildings become better sealed and more energy efficient, there is less ability

to vent moisture through cracks or gaps in the building structure. Therefore consideration of moisture in buildings is now more important than ever.

In areas of high moisture generation such as kitchens, bathrooms and laundries, exhaust fans should be provided to externally vent the moisture when the room is in use. It is recommended that the lining, e.g. plasterboard, in all areas be sealed and painted with two coats of washable paint. This will improve the vapour resistance of the internal lining. In tropical areas, the outdoor air is more humid and therefore it is better to use paint that is vapour permeable.

A building wrap is commonly placed around the exterior of the wall studs. The building wrap functions as an air and water barrier, and some wraps also assist in providing the insulation to the building.

### Bushfire resistance

Many homes in Australia may be subject to bushfire attack. These attacks can be resisted by both active and passive means, and the way you design and finish your home externally can have a big impact on its ability to survive a bushfire attack. The detailed construction requirements for various levels of expected bushfire attack by radiant heat, ember and flame contact are contained in the Australian Standard AS 3959 *Building in bushfire-prone areas*. Authorities in most states also publish information covering new construction, building alteration and bushfire preparedness in affected areas.

### Lightning

Emergency authorities usually recommend taking refuge inside buildings during electrical storms. Small buildings such as houses usually do not have dedicated lightning protection systems and so direct lightning strikes can cause significant damage to the building and its contents, and present risks to the lives of its occupants from electric shock and fire. A well-constructed steel-roofed steel-framed home offers considerable intrinsic protection from a lightning strike, and is less likely to ignite or suffer significant damage causing additional emergency consequences.

### Housekeeping - a reminder

Although you have now moved on from most of the 'heavy duty' construction processes, site safety and waste control remain just as important. On completion of each finishing stage, the affected area should be cleared and waste material disposed of safely and responsibly. Excess materials should be stacked and stored to allow for use at a later date - or sold locally to help someone else's project!

Don't forget that self-drilling screws create steel 'swarf' as they drill. Whilst not a problem in small quantities, when swarf gets into the wrong places it can mar the appearance of coated steel surfaces. It's a good idea to sweep away swarf progressively as you work, along with any discarded screws and small offcuts, to minimise any adverse effects. ■

### Typical tools for finishing operations

As we mentioned in the first article, the tools required for steel frame construction are familiar and readily available. This is what you're likely to need during the final stages of your project:

- A good quality battery screwdriver
- A pair of articulated snips
- Several toggle clamps
- A good quality level at least 1M long
- General hand tools

OB 149 - Part 1: *Why choose steel for your building project?*

TOB 150 - Part 2: *Construction aspects.* See also 'Steel' under subject listing for back issues, p.54 this issue.

Thanks to National Association of Steel-Framed Housing Inc (NASH) for providing the information for this article.



#### • NASH

A good source of information on suppliers and technical information. Visit their website for up to date information on residential and low-rise steel framed construction. Training is offered at some TAFEs for tradespeople wishing to gain expertise with steel framing. These courses may be suitable for owner builders with some experience in building. 1800 656 986, [www.nash.asn.au](http://www.nash.asn.au)

#### • Technosteel Australia

Manufacturer of steel house frames, roof trusses and floor systems, mainly for the owner builder. 1300 553 457 [www.technosteelaustralia.com](http://www.technosteelaustralia.com)

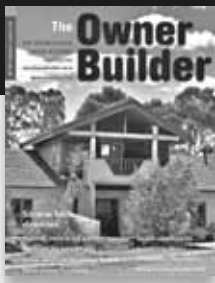

NOTE: The PDF file is generally around 8-9MB in size. You will need a broadband connection, and an email system that allows you to receive attached files up to 10MB in size.

## Subscriptions to *The Owner Builder* are now also available as an electronic PDF file

*A great new way to read your favourite magazine - as a fully searchable and printable PDF file sent direct to your email address!*

To subscribe, see order form on p.56

THE FOLLOWING OPTIONS ARE AVAILABLE:

**A. PDF file only** - \$33.00 for a year's subscription (6 issues).

Receive your magazine as an electronic PDF file, via email. See note below.

**B. Printed magazine plus PDF file** - \$55.00.\* Reap the benefits of full PDF searchability, while retaining the unique look and feel of the hard copy magazine.

**Hard copy only** - \$38.50.\* Of course, we will continue to offer the option of just a physical hard copy of the magazine every two months, as usual. Save 7.5% on the recommended retail price by subscribing.

If you would like **to upgrade an existing subscription to a PDF option**, please contact us by phone on 02 4995 8821 or email: [info@theownerbuilder.com.au](mailto:info@theownerbuilder.com.au)

\* For overseas pricing see order form on p.56